

ORCHARD & VINEYARD

rotary mowers - flail choppers - pruning sweeps - mechanical weed control



www.perfectvanwamel.com



PERFECT orchard and vineyard equipment

PERFECT rotary mowers and pulverisers have been designed and built since 1947 by Van Wamel BV in the Netherlands. Development and manufacturing are entirely carried out in-house, using the best materials and component and the skills and know-how of our engineers and technicians. All of this contributes to the high and consistent quality that PERFECT machines are known for. Van Wamel disposes of a worldwide network of PERFECT dealers and importers. Our partners are an indispensable link in the sales and service on PERFECT machines.



ROTARY MOWERS	3
> FIXED WIDTH	4
> VARIABLE WIDTH	7
> IN-ROW MOWERS	10
LAWN STRIP IMPROVEMENTS	15
SOLO-SWING IN-ROW MOWING DISKS	16
FLAIL CHOPPERS	21
PRUNINGS SWEEPS	24



3-point rear std,
front mount option



Front and 3-point
rear std



3-point rear



Front mount



Indication of required
tractor power (HP)



540 PTO drive speed (rpm)



V-belt drive



Gear drive



Side discharge possibility

ROTARY MOWERS

PERFECT rotary mowers

PERFECT offers the ideal rotary mower for every fruit or grape grower; our programme consists only of high quality machines, which have been designed to protect your crops in the best possible way. With a PERFECT mower you are sure of an extremely reliable mower which always does a good job, during many years.





VINIMO



- > Very manoeuvrable thanks to short and compact setup.
- > Two rotors with overlapping blades.
- > Robust driveline, to the right.
- > Side discharge possibility, to the right.

OPTIONS:

- > Front mount version 540/1000 rpm.



SPECIFICATIONS	VINIMO-105	VINIMO-125
Working width (m/feet)	1,05 (3'5")	1,25 (4'1")
Number of rotors	2	2
Total width (m)	1,13	1,33
Weight (kg/lbs)	185 / 410	220 / 485

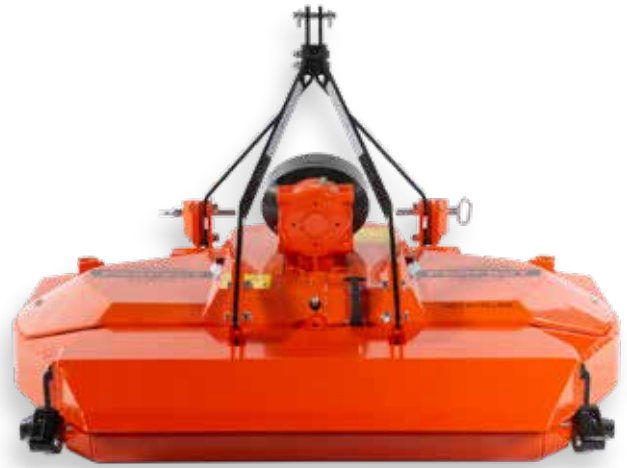

T



- > Three rotors, generous overlap.
- > Automatic v-belt tensioning.
- > Very compact and manoeuvrable.
- > Front wheel(s) and rear roller for excellent ground contour following.

OPTIONS:

- > Headstock for mowing and spraying in one pass.
- > Front mount version (trailed) or front/rear headstock.



SPECIFICATIONS	T-155	T-180	T-200	T-225	T-250	T-290
Working width (m/feet)	1,55 (5'2")	1,80 (5'11")	2,00 (6'7")	2,25 (7'5")	2,50 (8'3")	2,90 (9'6")
Number of rotors	3	3	3	3	3	3
Total width (m)	1,60	1,85	2,05	2,30	2,55	2,95
Weight (kg/lbs)	350	385	415	500	525	535



RN



- Double gearbox driveline; counter-rotating blades, high capacity.
- Automatic v-belt tensioners.
- Side discharge possibility (left + right).

OPTIONS:

- Hydraulic offset (parallelogram).
- Headstock for mowing and spraying in one pass.
- Front mount version (trailed) or front/rear headstock.
- Tandem rear roller and/or rubber front swivel wheels for optimal ground contour following in more uneven terrain.

SPECIFICATIONS	RN-180	RN-200	RN-225	RN-250	RN-290
Working width (m/feet)	1,80 (5'11")	2,00 (6'7")	2,25 (7'5")	2,50 (8'3")	2,90 (9'6")
Number of rotors	3	3	3	3	3
Max. offset (option) from tractor centre (m)	1,26	1,36	1,48	1,61	1,81
Total width (m)	1,85	2,05	2,30	2,55	2,95
Weight (kg/lbs)	415 / 915	460 / 1015	480 / 1060	530 / 1170	585 / 1290



TKF



- Flexible front-mount headstock; super short mount to any type of tractor.
- PTO speed 540, 750 or 1000 rpm, overrunning clutch integrated in gearbox, also for reversed-seat tractors.
- Counter-rotating blades, high capacity.
- Side discharge possibility (left + right).

OPTIONS:

- Rubber front swivel wheels.



SPECIFICATIONS	TKF-200	TKF-230	TKF-260
Working width (m/feet)	2,00 (6'7")	2,30 (7'7")	2,60 (8'8")
Number of rotors	4	4	4
Total width (m)	2,05	2,35	2,65
Weight (kg/lbs)	480 / 1060	540 / 1230	640 / 1400



LF



- Very robust construction.
- Profiled skids, driving speeds up to 10 km/h / 6,5 mph.
- Standard offset for a large mowing range.

OPTIONS:

- Hydraulic offset (parallelogram).
- Front mount version, trailed suspension.
- Rear roller, anti-scalp saucers for uneven terrain.
- Wheel set, various wheel types available.

SPECIFICATIONS	LF-140	LF-185	LF-215	LF-245	LF-275	LF-360
Working width (m/feet)	1,40 (4'7")	1,85 (6'1")	2,15 (7'1")	2,45 (8'1")	2,75 (9'0")	3,60 (11'10")
Number of rotors	2	3	3	3	3	4
Max. offset std (hydr. offset) (m)	0,70 (1,00)	1,40 (1,30)	1,55 (1,48)	1,70 (1,63)	1,85 (1,78)	2,30 (2,23)
Total width (m)	1,49	1,94	2,24	2,54	2,84	3,69
Weight (kg/lbs)	325 / 715	360 / 790	430 / 790	465 / 1025	520 / 1145	670 / 1475



LK



- Heavy duty driveline through gearboxes.
- Mows also very high, dense and/or tough vegetation.
- Driveline protected by rubber shock absorbers between the gearboxes and friction clutch on the PTO shaft.

OPTIONS:

- Rear roller.
- Hydraulic offset.
- Wheel set (various wheel types available).

SPECIFICATIONS	LK-185	LK-215	LK-245	LK-275
Working width (m/feet)	1,85 (6'1")	2,15 (7'1")	2,45 (8'1")	2,75 (9'0")
Number of rotors	3	3	3	3
Max. offset std (hydr. offset) (m)	1,40 (1,41)	1,56 (1,55)	1,71 (1,70)	1,86 (1,83)
Total width (m)	1,95	2,25	2,55	2,85
Weight (kg/lbs)	470 / 1035	490 / 1080	625 / 1375	700 / 1540





NEW!

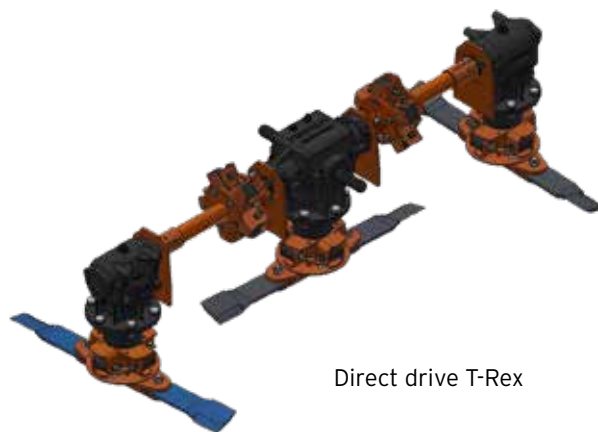

Direct drive T-Rex

T-Rex



- > Extremely strong construction made from high-quality materials
- > Equipped with three blades, keeping the mower compact
- > Floating cutting deck for optimal ground following
- > Gearbox drive for direct and powerful transmission, less wear and tear and a longer service life
- > With side discharge option (left + right)

OPTIONS:

- > Mow-spray combination
- > Hydraulic offset feature
- > Tandem roller
- > Full rubber wheels
- > Front mount or double frame for front mounting in front of the 3-point linkage

SPECIFICATIONS	T-REX 150	T-REX 165	T-REX 185	T-REX 200	T-REX 225	T-REX 245	T-REX 270	T-REX 290
Working width (m/feet)	1,50 (4'9")	1,65 (5'4")	1,85 (6'1")	2,00 (6'6")	2,25 (7'3")	2,45 (8'1")	2,70 (8'9")	2,90 (9'5")
Number of rotors	2	2	2	3	3	3	3	3
Max. offset (option)	1,00	1,08	1,18	1,25	1,38	1,48	1,60	1,70
Total width (m)	1,54	1,69	1,89	2,04	2,29	2,49	2,74	2,94
Weight (kg/lbs)	420 / 925	430 / 950	450 / 995	495 / 1090	530 / 1170	570 / 1255	630 / 1390	660 / 1455



T-REX 150

ROTARY MOWERS

Variable working width

In order to mow large and/or various row spacings PERFECT offers various solutions, ranging up to a 5,70 m working width. The proven adjustment mechanisms require low maintenance and have a very long lifespan.

Special features:

- Working width left and right individually adjustable. Counter-rotating blades; side discharge possibility to the left and right (mulching).





DR/MV



- Central frame with 2 (MV) or 3 (DR) rotors.
- Double gearbox drive; counter-rotating blades, high capacity, anti-scalp plates under the wing rotors.
- DR-570 with two support wheels on each wing.

OPTIONS:

- Headstock for mowing and spraying in one pass*.
- Front mount headstock (trailed suspension) or front/rear headstock*.
- Adjustable wing angle (max. 15 degrees)*.
- Rubber wheels on the central frame, standard on DR-440/480/570.
*not on DR-570

SPECIFICATIONS	DR-250	DR-280	MV-280	DR-320
Working width (m/feet)	1,50-2,50 (4'10"-8'3")	1,75-2,80 (5'9"-9'2")	1,90-2,80 (6'3"-9'2")	1,90-3,20 (6'3"-10'6")
Number of rotors	2+2	3+2	2+2	3+2
Total width (m)	1,61	1,78	1,93	1,93
Weight (kg/lbs)	540 / 1190	600 / 1325	580 / 1275	615 / 1355

SPECIFICATIONS	MV-320	DR-365	DR-405
Working width (m/feet)	1,95-3,20 (6'5"-10'6")	2,25-3,65 (7'5"-12'0")	2,45-4,05 (8'2"-13'4")
Number of rotors	2+2	3+2	3+2
Total width (m)	2,05	2,28	2,48
Weight (kg/lbs)	625 / 1375	660 / 1455	710 / 1565

SPECIFICATIONS	DR-440	DR-480	DR-570
Working width (m/feet)	2,90-4,40 (9'7"-14'5")	2,90-4,80 (9'7"-15'9")	2,90-5,70 (9'7"-18'8")
Number of rotors	3+2	3+2	3+4
Total width (m)	3,00	3,00	3,00
Weight (kg/lbs)	740 / 1630	825 / 1820	1100 / 2425

OPTION: SPRAY-UNIT

Specifications:

- Mows the strip next to the mower in a single pass.
- Suitable for almost all PERFECT models.
- Fuel tank capacity 120 litres + fresh water tank.
- 12 V pump + filter.
- 2x nozzle supports with collision protection.
- Electric control and E-valve.
- Pressure gauge.
- Rotary switch.
- Various pipes.
- Impact protection with a spray hood on both sides beneath the trees (mulching).



Impact protection with spray hood



VT



- > Very high capacity, high working speed, also in tall grass.
- > Direct gearbox drive, high rotor torque.
- > PTO shaft with friction and overrunning clutch.
- > Side discharge.

OPTIONS:

- > Hydraulic offset (displacing the entire mower).
- > Tandem roller and/or rubber front swivel wheels.
- > DC valve for simultaneous width adjustment left and right.
- > Extra large roller (22 cm).

SPECIFICATIONS	VT-145	VT-180	VT-225	VT-260
Working width (m/feet)	1,15-1,45 (3'9"-4'9")	1,33-1,80 (4'4"-5'11")	1,65-2,25 (5'5"-7'5")	1,90-2,60 (6'3"-8'6")
Number of rotors	2	2	2	2
Total width (m)	1,18-1,48	1,36-1,83	1,68-2,28	1,93-2,63
Weight (kg/lbs)	450 / 990	460 / 1000	640 / 1410	700 / 1540

SPECIAL NEW OPTION: MOW-SPRAY*

- > Floating suspension.
 - > Disconnectable gearbox.
 - > 540-430 rpm EFFECTIVE SPRAYING.
 - > Fuel-saving.
- *not possible on VT-145



VT-260 with Mow-Spray option



VT-145



ROTARY MOWERS

Options

BLADES:

- PERFECT mowers are fitted with swing-away blades which give excellent protection against stones etc.



Fixed blades on Vinimo, TKF, MV, MD/DR-250, FV2-160/195/220.

MOW-SPRAY HEADSTOCK:

- Mowing and spraying in one pass; the sprayer weight is entirely transferred to the tractor lift arms. The mower is independently suspended below the headstock. Also available with disconnectable gearboxes in order to stop the blades from turning whilst filling up the sprayer.

Available on T, RN, DR/MV and VT.

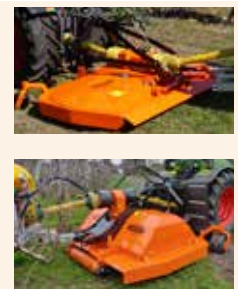

FRONT MOUNT (TRAILED) / FRONT + REAR HEADSTOCK:

- Excellent ground contour following thanks to the 'trailed' suspension.

Available on T, RN, DR/MV, LF, FV2.



HYDRAULIC OFFSET (PARALLELOGRAM):

- Stepless adjustable offset; maximal offset 30 cm to the left and right.

Available on RN, LF, LK, DR/MV, VT and MD.



WHEEL SETS:

- Various pneumatic or foam-filled tires available.

Available on any model.



TANDEM ROLLER:

- The (pendulum mount) rear rollers give an excellent ground contour following in uneven terrain, enabling smoother work at higher working speeds.

Available on RN, DR, VT, MD.





ROTARY MOWERS WITH IN-ROW MOWING DISK

In-row mowers

In-row mowing is a proven way of mechanical weed control in the tree/vine row. With various models and many working widths available, PERFECT offers the right solution for every orchard and vineyard. PERFECT mowers with in-row mowing disks are known for their very long lifespan and excellent reliability; this is due to the entire in-house design and manufacturing of the swinging mechanism parts.

The resistance of the swinging mechanism can be easily adjusted by changing the the position of the spring. The mowing disk itself can turn when it touches the tree, this ensures that the tree or vine does not suffer any damage.

Options:

- Hydraulic feeler bar to mow around young trees/vines or in order to work on sloping terrain >5%.
- Hydraulic adjustment of the swing arm; this system enables to limit the maximum reach of the mowing disk, the swinging effect remains unchanged.
- Raisable mowing disk, in order to work in orchards/vineyards where the trees or vines are planted on a ridge. The disk can be placed under an angle (max. 15 degrees) and is fixed with a spindle mechanism.





RF



- Large offset.
- Super-low mower frame in order to mow under low branches.
- Heavy v-belt drive with automatic belt tensioners.
- Adjustable front swivel wheels and rear roller for an excellent ground contour following.

OPTIONS:

- Hydraulic feeler bar for young trees or sloping terrain.
- Hydraulic swing arm adjustment.
- Raisable mowing disk (max. 15 degrees).
- Rubber front swivel wheels.
- Front mount version 540/1000 rpm.
- Hydraulic offset.

SPECIFICATIONS	RF-220	RF-270	RF-300	RF-325	RF-340	RF-365
Working width (m/feet)	2,20 (7'3")	2,70 (8'10")	3,00 (9'10")	3,25 (10'8")	3,40 (11'2")	3,65 (12'0")
Number of rotors	2+1	3+1	3+1	3+1	4+1	4+1
Mowing disk diameter (m)	60	60	60	85	60	85
Max. offset from tractor centre	2,15	2,30	2,55	2,80	2,97	3,22
Weight (kg/lbs)	495 / 1090	600 / 1320	610 / 1345	675 / 1490	715 / 1575	730 / 1610



MD



- Double gearbox drive; counter-rotating blades, high capacity.
- Heavy v-belt drive with automatic belt tensioners.
- Adjustable front swivel wheels and rear roller for excellent ground contour following.
- Side discharge possibility (left + right).
- Diameter of the mowing disks 60 cm / 2ft (MD-440; 85 cm / 2'8").

OPTIONS:

- Hydraulic feeler bars for young trees / sloping terrain.
- Hydraulic swing arm adjustment.
- Raisable mowing disks (max. 15 degrees).
- Tandem roller and/or rubber front swivel wheels.
- Hydraulic offset.

SPECIFICATIONS	MD-250	MD-280	MD-300	MD-335	MD-355	MD-400	MD-440
Min. working width (m/feet)	1,60 (4'11")	1,75 (5'9")	1,90 (6'3")	2,25 (7'5")	2,45 (8'2")	2,90 (9'7")	2,90 (10'5")
Max. working width (m/feet)	2,50 (8'3")	2,80 (9'2")	3,00 (9'10")	3,35 (11'0")	3,55 (11'8")	4,00 (13'1")	4,40 (14'5")
Number of rotors	2+2	3+2	3+2	3+2	3+2	3+2	3+2
Total width (m)	1,70	1,78	1,93	2,28	2,48	3,00	3,00
Weight (kg/lbs)	505 / 1115	535 / 1180	560 / 1235	565 / 1245	620 / 1370	740 / 1630	800 / 1772



FV2



- For vineyards, berry cultures etc.
- Entirely mechanical driveline, extremely reliable.
- Double gearbox drive; counter-rotating blades, high capacity.
- Side discharge possibility (left and right).

OPTIONS:

- Hydraulic swing arm adjustment.
- Raisable mowing disks (max. 15 degrees).
- Hydraulic feeler bars for young vines and/or sloping terrain (on FV2-250-...-FV2-365).
- Front mount version 540/1000 rpm.

SPECIFICATIONS	FV2-160	FV2-195	FV2-220	FV2-250
Min.-max. working width (m/feet)	1,20-1,60 (4'0"-5'3")	1,25-1,95 (4'1"-6'5")	1,47-2,20 (4'11"-7'3")	1,75-2,50 (5'9"-8'3")
Number of rotors	2+2	2+2	2+2	3+2
Total width (m)	1,23	1,50	1,93	2,48
Weight (kg/lbs)	300 / 660	430 / 950	460 / 1015	515 / 1135

SPECIFICATIONS	FV2-265	FV2-300	FV2-320	FV2-365
Min.-max. working width (m/feet)	1,90-2,65 (6'3"-8'8")	2,25-3,00 (7'5"-9'10")	2,45-3,20 (8'1"-10'6")	2,94-3,65 (9'7"-12'0")
Number of rotors	3+2	3+2	3+2	3+2
Total width (m)	1,93	2,28	2,48	3,00
Weight (kg/lbs)	520 / 1145	555 / 1225	615 / 1355	660 / 1455



ENSURING HEALTHY SOIL

PERFECT Lawn Strip Improvements

As well as mowing, there are other ways to keep your land healthy. Below are a number of options from our product range that help ensure healthy soil.



WBG 2 - Grassland subsoiler

With the Perfect grassland subsoiler, you eliminate soil compaction while keeping the sward intact. The water absorption capacity of the soil improves, making the grassrow easier to drive in the spring. The improved soil structure also makes sure that the sward retains the good grasses for longer, so the (relatively expensive) overseeding process can be postponed or even omitted altogether.



GB - Aerator

The Perfect aerator for orchards and vineyards effortlessly removes compaction in the soil structure and improves the permeability of the sward.



Terra Ranger - In-Row Tiller

Highly efficient weed cutter/weeder developed for in-row weed control. Suitable for use in fruit growing and viticulture with row spacings of 2.5 to 4.0 m.



Skyros Vario - Disc harrows

The innovative, continuously variable angle adjustment of the Perfect disc harrows makes that the machines can be accurately adjusted to perform the given tasks. Deep or shallow cultivation, plenty or little crop residue, dry or wet soil: the Vario-Disc harrows work hassle-free under any circumstances. The discs have maximum effect by adjusting the angle of the discs for each row.



SOLO-SWING MOWING DISKS

PERFECT Solo-Swing

The hydraulic drive of our Solo-Swing mowing disks offers a broad range of mounting possibilities.



Specific characteristics:

- Robust, compact construction.
- Height of disk/motor 23/32 cm (mowing height set at 6 cm).
- Heavy swing-away mowing blades.
- Raisable swing arm (working angle max. 15 degrees).
- Protection disk with integrated bearing under the rotor.

Options:

- Hydraulic feeler bar; for use with young trees and/or on slopes >5 degrees.





SZA-600

SZA

- To mount on a rotary/flail mower, wheel loader or any other carrier.
- Available with cutting disk of 42, 50, 60 and 85 cm.
- Required oil flow 30 l/min.



SZX-850

SZX

- Hydraulic offset (parallelogram).
- Pendulum-mount support wheels for an excellent ground contour following.
- Required oil flow 30 l/min.
- 60/85 cm cutting disk, for use in front linkage.
- Heavy headstock (Cat. II), max. offset 2,45 m.

OPTIONS:

- Rear version.
- Hydraulic feeler bar for use in young trees or sloping terrain > 5%.



OPTIONS:

- Hydraulic feeler bar for use in young trees or sloping terrain.



SZS-600

SZS

- 3-point headstock (rear), quick and easy mount/release.
- 60 or 85 cm cutting disk.
- Hydraulic offset.
- Pendulum-mount support wheels for an excellent ground contour following.
- Max. offset 2.10 m (SZS-600) / 2.22 m (SZS-850).

OPTIONS:

- Hydraulic feeler bar for use in young trees or sloping terrain.



DUO-SWING

- 3-point headstock (rear), Cat. I/II.
- Working width cutting discs two times 42, 50 or 60 cm.
- Doppel hydraulic offset.
- Maximum working range because of mechanical sliding
- Adjustment possibility in the headstock
- Two set of pendulum-mount support wheels for an excellent ground contour following .
- Required oil flow 30 l.min.
- Working range 173 - 463 cm (model 42), 173-472 cm (model 50), 173 - 484 cm (model 60).
- For plantings from 200 up to 450 cm row width.

OPTIONS:

- 3-point headstock for front linkage Cat. I + II.
- Hydraulic feeler bar for use in young trees or sloping terrain > 5%.



PRUNINGS CHOPPERS

PERFECT prunings choppers

PERFECT prunings choppers can shred prunings as thick as 10 cm/4". The combination of a heavy rotor and a high rotation speed caters for an unrivalled shredding, also large quantities of prunings are processed without any problem. With various models ranging from 0,90 m up to 4,60 m PERFECT offers the right prunings shredder for just about any type of orchard or vineyard.

Characteristics:

- Very strong construction, built from top quality materials.
- Heavy duty flail shaft and flails for a maximum impact.
- Very fine shredding of prunings up to \varnothing 10 cm requiring relatively low tractor power.
- Automatic v-belt tensioning (on most models) for a continuously available slashing power.



PRUNINGS SHREDDERS

Flails/flail rotor

PERFECT flails are cast from a special steel and boron alloy, which makes that the cutting edge hardens when it gets in contact with the shredding material. The result is a great performance and a long life.

Multiple flail types

- **0,9 kg/2,5 lbs flail;** for grass, vegetation and prunings up to \varnothing 3 cm/1 1/4 ". Excellent cut in grass.
- **2,2 kg/5 lbs flail;** to shred prunings of max. \varnothing 10 cm/4". Great slashing power. Even withstands impact of stones. Extra wide mount.
- **Combi-flail;** extra heavy flail (2,7 kg/6 lbs) with replaceable cutting blade. For extra fine shredding, also of thicker material. Also a great cut in grass. One saves over 20% when replacing flails.



Pro-Fix flail mount

The Pro-Fix flail mount offers great added value in terms of protecting the flail rotor in very difficult working conditions. When the rotor gets in contact with a big stone, tree stump or other large and hard object, this guiding system from hardened steel prevents the flail attachment points from being damaged/removed from the flail shaft.

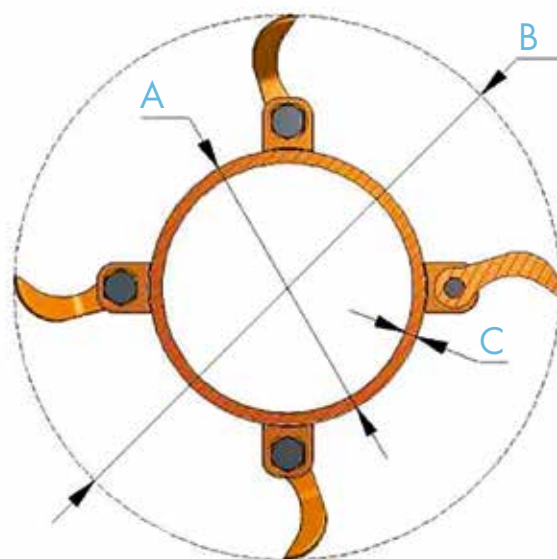

MODEL	A Ø FLAIL SHAFT	B Ø ROTOR	C THICKNESS (MM)
KD / BG2-BK2 / VARIOCHOP	140	407	12,5
KG-KK 150/180/220	178	445	14,2
KG-KK 245HD	219	485	12,5
NX-460	160	427	12,5

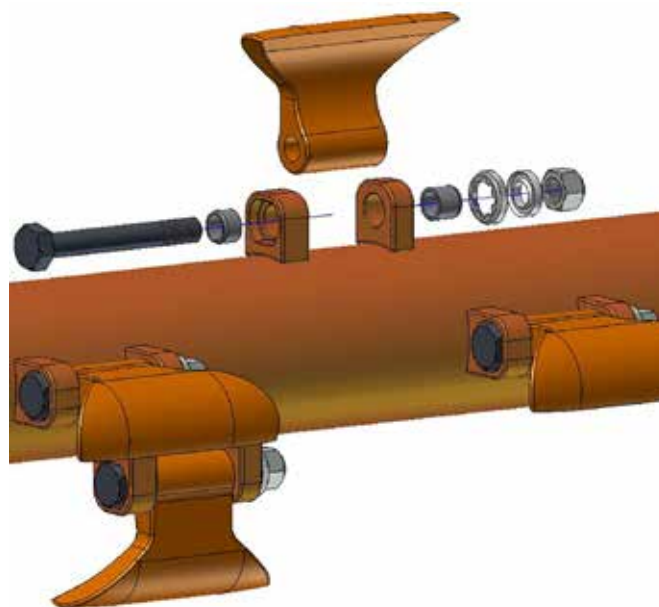

Unique flail mount

The flail suspension of PERFECT prunings shredders comprises hardened steel bushings between the flail ears and the flail bolt. Thanks to these bushings the flail ear does not wear out hence does not require replacing. Not having to grind and weld on a flail shaft preserves the balance of the rotor which extends the lifespan of the machine.



BG2/BK2



- Heavy duty prunings shredder for prunings of up to \varnothing 8 cm.
- Super-low frame and drive train, height 51 cm.
- Automatic v-belt tensioner for continuously available slashing power.
- Standard offset facility (parallelogram).

OPTIONS:

- Hydraulic offset.
- Front mount version (trailed suspension).
- Twin skin / leaf shredding plate.
- Combi-flails.
- Extra large roller \varnothing 22 cm (std 15 cm).



VARIOCHOP



- Front and rear mount.
- Hydraulic offset 48 cm.
- Adjustable PTO speed by reversing v-belt pulleys; PTO speed 540/750/1000 rpm.
- Gearbox with integrated overrunning clutch; also for reverse seat tractors.

OPTIONS:

- Rake tines.
- Twin skin / leaf shredding plate.
- Combi-flails.
- Extra large roller \varnothing 22 cm (std 15 cm).

SPECIFICATIONS	VARIOCHOP-135	VARIOCHOP-150	VARIOCHOP-180	VARIOCHOP-210
Working width (m/feet)	1,35 (4'4")	1,50 (4'11")	1,80 (5'11")	2,10 (6'11")
Flails (number)	8	9	12	12
Total width (m)	1,57	1,72	2,02	2,32
Max offset from tractor centre (m)	0,68	0,99	1,29	1,59
Weight (kg/lbs)	660 / 1455	700 / 1540	740 / 1630	810 / 1785

SPECIFICATIONS: BG2/BK2	BK2-090	BG2/BK2-105	BG2/BK2-120	BG2/BK2-135	BG2/BK2-150	BG2/BK2-180	BG2/BK2-210
Working width (m/feet)	0,90 (2'11")	1,05 (3'5")	1,20 (3'11")	1,35 (4'5")	1,50 (4'11")	1,80 (5'11")	2,10 (6'11")
Flails (number)	6	6	8	8	9	12	12
Total width (m)	1,10	1,28	1,43	1,58	1,73	2,03	2,33
Max offset from tractor centre (m)	0,56	0,62	0,80	0,95	1,10	1,40	1,70
Weight (kg/lbs)	385 (850)	480/500 (1060/1100)	510/535 (1125/1180)	525/550 (1160/1215)	550/590 (1210/1300)	640/665 (1410/1465)	725/800 (1600/1765)



KG / KK



- Heavy duty prunings shredder.
- 2,2 kg / 5 lbs. flails, for prunings up to ø 10 cm.
- Standard offset system (parallelogram).
- Driveline with 4 v-belts with automatic tensioning system.
- KG/KK-245HD with an extra heavy gearbox, pto shaft, extra large flail shaft and rear roller.
- KK with adjustable rear hood and rake tines possibility.

OPTIONS:

- Hydraulic offset.
- Front mount (trailed suspension).
- Twin skin / leaf shredding plate.
- Combi-flails.
- Rake tines (on KK).
- Pro-Fix flail mounting.
- Side discharge (on KK).



SPECIFICATIONS	KG/KK-150	KG/KK-180	KG/KK-220	KG/KK-245HD
Working width (m/feet)	1,50 (4'11")	1,80 (5'11")	2,20 (6'11")	2,45 (8'1")
Flails (number)	9	12	12	16
Total width (m)	1,71	2,10	2,50	2,75
Max offset from tractor centre (m)	1,12	1,42	1,82	1,81
Weight (kg/lbs)	750/770 (1650/1705)	780/815 (1760/1795)	795/865 (1880/1905)	990/1035 (2185/2280)



VINICHOP



- Wood chopper for use in viticulture or soft fruit cultivation
- Available with 0.9 kg flails, for pruning waste up to 3 cm thick
- Standard rake tines
- Standard mechanical offset feature
- Drive via 4 V-belts
- Cover for easy maintenance
- Tractor linkage cat. I + II

OPTIONS:

- Hydraulic offset
- Front and rear mount models 1000 rpm



SPECIFICATIONS	90	105	120	130	140	160	180
Working width (m/feet)	0,90 (2'11")	1,05 (3'5")	1,20 (3'11")	1,30 (4'3")	1,40 (4'7")	1,60 (5'3")	1,80 (5'11")
Number of flails	10	12	14	15	16	18	20
Total width (m)	1,10	1,25	1,40	1,50	1,60	1,80	2,00
Rake tines (amount)	7	8	9	10	10	12	13
Weight (kg/lbs)	315 / 693	325 / 715	350 / 770	365 / 803	375 / 825	400 / 880	445 / 980



KD



- Compact, robust construction for prunings up to \varnothing 3 cm.
- 0,9 kg / 2 lbs flails and rake tines.
- Offset facility (second headstock mounting point).

OPTIONS:

- Hydraulic offset.
- Front mount 540/1000 rpm.
- Pro-Fix flail mount.
- Overrun clutch.



NX-460



- Working width steplessly adjustable from 2,90 - 4,60 m.
- Two robust flail mowers of 2,40 m each.
- Independent, trailed suspension for an optimal ground contour following.
- 2,2 kg / 5 lbs flails for grass and prunings of up to \varnothing 8 cm.

OPTIONS:

- Active hydraulic steering for a reduced turning radius.
- 0,9 kg / 2 lb flails for a great cut in grass.
- Combi-flails.



SPECIFICATIONS	KD-150	KD-180	KD-210	KD-240
Working width (m/feet)	1,50 (4'11")	1,80 (5'11")	2,10 (6'11")	2,40 (7'11")
Flails (number)	16	18	22	24
Total width (m)	1,73	2,03	2,22	2,68
Max offset from tractor centre (m)	0,80	1,27	1,42	1,60
Weight (kg/lbs)	460 / 1010	500 / 1100	590 / 1300	685 / 1505

SPECIFICATIONS	NX-460
Working width min.-max. (m/feet)	2,90-4,60 (9'6" - 15'1")
Number of flails (2,2 / 0,9 kg)	32/48
Transport width (m)	3,00
Weight (kg/lbs)	2100 / 4620



PRUNINGS SWEEPS

PERFECT prunings sweeps

PERFECT prunings sweeps remove prunings and leaves from the tree / vine row.

PERFECT prunings sweeps are equipped with a swivel wheel which gives a precise ground contour following, independently from the tractor or shredder.

Standard on every prunings sweep:

- › Swivel wheel for optimal ground contour following.
- › Working angle and height adjustable for a great result in any condition.
- › Standard working radius 100 cm, alternatively 130 or 58 cm (vineyards).
- › Also available with rubber paddles and support saucer instead of brushes.





MOUNT-ON SWEEP

SPA

TO MOUNT ON A PRUNINGS CHOPPER

- Incl. mounting plate to fit the sweep on a prunings chopper.

OPTIONS:

- Hydraulic lift.
- Adjustable width (manually).
- Rubber paddles and support saucer.



POETSER FRONTAANBOUW

SPF

TO INSTALL ON THE TRACTOR FRONT

- Mounting beam to install on the tractor front.
- Front linkage not necessary.

OPTIONS:

- Hydraulic lift.
- Hydraulic width adjustment.
- Headstock for front and rear linkage incl. extra working width adjustment.
- Rubber paddles with support saucer.





DOUBLE BRUSH SWEEP

SPD

FRONT MOUNT, ALSO ON TRACTORS WITHOUT FRONT LINKAGE

- Sweeps the tree strips on both sides in one pass.
- Total working with max. 5.15 m (table).
- Mounting beam to fit to the front of the tractor, front linkage not necessary.
- Hydraulic lift of the sweeper heads, working width hydr. adjustable.
- Necessary hydraulic couplings: 4 x DA or 3 x DA and 1 x SA.

OPTIONS:

- Headstock for front/rear linkage.
- Rubber paddles and support saucers.

WORKING WIDTH DOUBLE PRUNINGS SWEEP SPD

	Brush diameter (cm)	Working width min.-max
Standard version (mounting beam)	58	1,40-4,04 m
	100 (std.)	2,20-4,45 m
	130	2,80-4,75 m
With headstoc front/rear linkage	58	1,40-4,43 m
	130	2,80-5,15 m

NOTES



📍 **PERFECT Van Wamel B.V.**
Energieweg 1, 6658 AE
Beneden Leeuwen
The Netherlands

☎ +31 (0) 487 59 29 44
@ www.perfectvanwamel.com
🌐 sales@vanwamel.nl

Your PERFECT partner